

# MICRO CUBE

## Owner's Manual

Thank you, and congratulations on your choice of the Roland MICRO CUBE Guitar Amplifier.

Before using this unit, carefully read the sections entitled:

- USING THE UNIT SAFELY (p. 2–4)
- IMPORTANT NOTES (p. 5)

These sections provide important information concerning the proper operation of the unit. Additionally, in order to feel assured that you have gained a good grasp of every feature provided by your new unit, Owner's manual should be read in its entirety. The manual should be saved and kept on hand as a convenient reference.

### Main Features

- This compact yet highly functional DSP guitar amp features a 12 cm (5 inches) speaker and outputs 2 watts.
- Powered either by six AA batteries or the included AC adaptor, you can use the MICRO CUBE to perform just about anywhere, with up to 20 hours of battery-powered playing time (with alkaline batteries; battery life may vary according to playing conditions).
- Comes equipped with a newly developed digital "TUNING FORK," which you can use to tune your guitar. This function includes three tuning key options (normal/half step down/whole step down). It can also be used for heavy bottom tunings.
- Offers six different COSM amp types.  
Amps included: ACOUSTIC / JC CLEAN / BLACK PANEL / BRIT COMBO / CLASSIC STACK / R-FIER STACK



**Composite Object Sound Modeling (COSM)** is Roland's innovative and powerful sound modeling technology. COSM analyzes the many factors that make up the original sound, such as the electrical and physical characteristics of the original, and then produces a digital model that can reproduce the same sound.

- The amp also accepts microphone input, allowing you to use the MICRO CUBE as a portable microphone amp.
- Onboard EFX section includes 4 types of digital effect, chorus, flanger, phaser and tremolo.
- Separate "DELAY" and "REVERB" effects provided in addition to the EFX.
- Equipped with "REC OUT jack" convenient for use in recording and for use as headphone out.
- Offers two types of jacks for external input; a 1/4" phone jack and a mini jack. This allows you to connect CD players and other backing devices.
- Also included is a handy strap for greater portability.







# USING THE UNIT SAFELY

## INSTRUCTIONS FOR THE PREVENTION OF FIRE, ELECTRIC SHOCK, OR INJURY TO PERSONS

About  WARNING and  CAUTION Notices

 <b>WARNING</b>	Used for instructions intended to alert the user to the risk of death or severe injury should the unit be used improperly.
 <b>CAUTION</b>	Used for instructions intended to alert the user to the risk of injury or material damage should the unit be used improperly.  * Material damage refers to damage or other adverse effects caused with respect to the home and all its furnishings, as well to domestic animals or pets.

About the Symbols

	The  symbol alerts the user to important instructions or warnings. The specific meaning of the symbol is determined by the design contained within the triangle. In the case of the symbol at left, it is used for general cautions, warnings, or alerts to danger.
	The  symbol alerts the user to items that must never be carried out (are forbidden). The specific thing that must not be done is indicated by the design contained within the circle. In the case of the symbol at left, it means that the unit must never be disassembled.
	The  symbol alerts the user to things that must be carried out. The specific thing that must be done is indicated by the design contained within the circle. In the case of the symbol at left, it means that the power-cord plug must be unplugged from the outlet.

### ALWAYS OBSERVE THE FOLLOWING

#### WARNING

- Before using this unit, make sure to read the instructions below, and the Owner's Manual. 



---

- Do not open (or modify in any way) the unit or its AC adaptor. 

---

- Do not attempt to repair the unit, or replace parts within it (except when this manual provides specific instructions directing you to do so). Refer all servicing to your retailer, the nearest Roland Service Center, or an authorized Roland distributor, as listed on the "Information" page. 

---

- Never use or store the unit in places that are: 
  - Subject to temperature extremes (e.g., direct sunlight in an enclosed vehicle, near a heating duct, on top of heat-generating equipment); or are 
  - Damp (e.g., baths, washrooms, on wet floors); or are
  - Humid; or are
  - Exposed to rain; or are
  - Dusty; or are
  - Subject to high levels of vibration.

#### WARNING

- Make sure you always have the unit placed so it is level and sure to remain stable. Never place it on stands that could wobble, or on inclined surfaces. 

---

- Be sure to use only the AC adaptor supplied with the unit. Also, make sure the line voltage at the installation matches the input voltage specified on the AC adaptor's body. Other AC adaptors may use a different polarity, or be designed for a different voltage, so their use could result in damage, malfunction, or electric shock. 

---

- Do not excessively twist or bend the power cord, nor place heavy objects on it. Doing so can damage the cord, producing severed elements and short circuits. Damaged cords are fire and shock hazards! 

 **WARNING**

- This unit, either alone or in combination with an amplifier and headphones or speakers, may be capable of producing sound levels that could cause permanent hearing loss. Do not operate for a long period of time at a high volume level, or at a level that is uncomfortable. If you experience any hearing loss or ringing in the ears, you should immediately stop using the unit, and consult an audiologist.



- Do not allow any objects (e.g., flammable material, coins, pins); or liquids of any kind (water, soft drinks, etc.) to penetrate the unit.



- Immediately turn the power off, remove the AC adaptor from the outlet, and request servicing by your retailer, the nearest Roland Service Center, or an authorized Roland distributor, as listed on the “Information” page when:



- The AC adaptor or the power-supply cord has been damaged; or
- If smoke or unusual odor occurs
- Objects have fallen into, or liquid has been spilled onto the unit; or
- The unit has been exposed to rain (or otherwise has become wet); or
- The unit does not appear to operate normally or exhibits a marked change in performance.

- In households with small children, an adult should provide supervision until the child is capable of following all the rules essential for the safe operation of the unit.



- Protect the unit from strong impact. (Do not drop it!)



 **WARNING**

- Do not force the unit’s power-supply cord to share an outlet with an unreasonable number of other devices. Be especially careful when using extension cords—the total power used by all devices you have connected to the extension cord’s outlet must never exceed the power rating (watts/ amperes) for the extension cord. Excessive loads can cause the insulation on the cord to heat up and eventually melt through.



- Before using the unit in a foreign country, consult with your retailer, the nearest Roland Service Center, or an authorized Roland distributor, as listed on the “Information” page.



- Batteries must never be recharged, heated, taken apart, or thrown into fire or water.



 **CAUTION**

- The unit and the AC adaptor should be located so their location or position does not interfere with their proper ventilation. 

---

- Always grasp only the output plug or the body of the AC adaptor when plugging into, or unplugging from, this unit or an outlet. 

---

- At regular intervals, you should unplug the AC adaptor and clean it by using a dry cloth to wipe all dust and other accumulations away from its prongs. Also, disconnect the power plug from the power outlet whenever the unit is to remain unused for an extended period of time. Any accumulation of dust between the power plug and the power outlet can result in poor insulation and lead to fire. 

---

- Try to prevent cords and cables from becoming entangled. Also, all cords and cables should be placed so they are out of the reach of children. 

---

- Never climb on top of, nor place heavy objects on the unit. 

---

- Never handle the AC adaptor body, or its output plugs, with wet hands when plugging into, or unplugging from, an outlet or this unit. 

---

- Before moving the unit, disconnect the AC adaptor and all cords coming from external devices. 



---

- Before cleaning the unit, turn off the power and unplug the AC adaptor from the outlet (p. 8). 

 **CAUTION**

- Whenever you suspect the possibility of lightning in your area, disconnect the AC adaptor from the outlet. 

---

- If used improperly, batteries may explode or leak and cause damage or injury. In the interest of safety, please read and observe the following precautions.   

  - Carefully follow the installation instructions for batteries, and make sure you observe the correct polarity. 
  - Avoid using new batteries together with used ones. In addition, avoid mixing different types of batteries.
  - Remove the batteries whenever the unit is to remain unused for an extended period of time.
  - If a battery has leaked, use a soft piece of cloth or paper towel to wipe all remnants of the discharge from the battery compartment. Then install new batteries. To avoid inflammation of the skin, make sure that none of the battery discharge gets onto your hands or skin. Exercise the utmost caution so that none of the discharge gets near your eyes. Immediately rinse the affected area with running water if any of the discharge has entered the eyes.
  - Never keep batteries together with metallic objects such as ballpoint pens, necklaces, hairpins, etc.

---

- Used batteries must be disposed of in compliance with whatever regulations for their safe disposal that may be observed in the region in which you live. 

# IMPORTANT NOTES

In addition to the items listed under “USING THE UNIT SAFELY” on page 2–4, please read and observe the following:

## Power Supply: Use of Batteries

- Do not use this unit on the same power circuit with any device that will generate line noise (such as an electric motor or variable lighting system).
- The AC adaptor will begin to generate heat after long hours of consecutive use. This is normal, and is not a cause for concern.
- The use of an AC adaptor is recommended as the unit’s power consumption is relatively high. Should you prefer to use batteries, please use the alkaline type.
- When installing or replacing batteries, always turn off the power on this unit and disconnect any other devices you may have connected. This way, you can prevent malfunction and/or damage to speakers or other devices.
- Before connecting this unit to other devices, turn off the power to all units. This will help prevent malfunctions and/or damage to speakers or other devices.

## Placement

- Using the unit near power amplifiers (or other equipment containing large power transformers) may induce hum. To alleviate the problem, change the orientation of this unit; or move it farther away from the source of interference.
- This device may interfere with radio and television reception. Do not use this device in the vicinity of such receivers.
- Noise may be produced if wireless communications devices, such as cell phones, are operated in the vicinity of this unit. Such noise could occur when receiving or initiating a call, or while conversing. Should you experience such problems, you should relocate such wireless devices so they are at a greater distance from this unit, or switch them off.
- Do not expose the unit to direct sunlight, place it near devices that radiate heat, leave it inside an enclosed vehicle, or otherwise subject it to temperature extremes. Also, do not allow lighting devices that normally are used while their light source is very close to the unit (such as a piano light), or powerful spotlights to shine upon the same area of the unit for extended periods of time. Excessive heat can deform or discolor the unit.
- When moved from one location to another where the temperature and/or humidity is very different, water droplets (condensation) may form inside the unit. Damage or malfunction may result if you attempt to use the unit in this condition. Therefore, before using the unit, you must allow it to stand for several hours, until the condensation has completely evaporated.
- Do not allow rubber, vinyl, or similar materials to remain on the unit for long periods of time. Such objects can discolor or otherwise harmfully affect the finish.

- Do not paste stickers, decals, or the like to this instrument. Peeling such matter off the instrument may damage the exterior finish.

## Maintenance

- For everyday cleaning wipe the unit with a soft, dry cloth or one that has been slightly dampened with water. To remove stubborn dirt, use a cloth impregnated with a mild, non-abrasive detergent. Afterwards, be sure to wipe the unit thoroughly with a soft, dry cloth.
- Never use benzene, thinners, alcohol or solvents of any kind, to avoid the possibility of discoloration and/or deformation.

## Additional Precautions

- Use a reasonable amount of care when using the unit’s buttons, sliders, or other controls; and when using its jacks and connectors. Rough handling can lead to malfunctions.
- When connecting / disconnecting all cables, grasp the connector itself—never pull on the cable. This way you will avoid causing shorts, or damage to the cable’s internal elements.
- To avoid disturbing your neighbors, try to keep the unit’s volume at reasonable levels. You may prefer to use headphones, so you do not need to be concerned about those around you (especially when it is late at night).
- When you need to transport the unit, package it in the box (including padding) that it came in, if possible. Otherwise, you will need to use equivalent packaging materials.
- Use a cable from Roland to make the connection. If using some other make of connection cable, please note the following precautions.
  - Some connection cables contain resistors. Do not use cables that incorporate resistors for connecting to this unit. The use of such cables can cause the sound level to be extremely low, or impossible to hear. For information on cable specifications, contact the manufacturer of the cable.
- To prevent malfunction and/or damage to speakers or other devices, always turn down the volume, and turn off the power on all devices before making any connections.

# Panel Descriptions

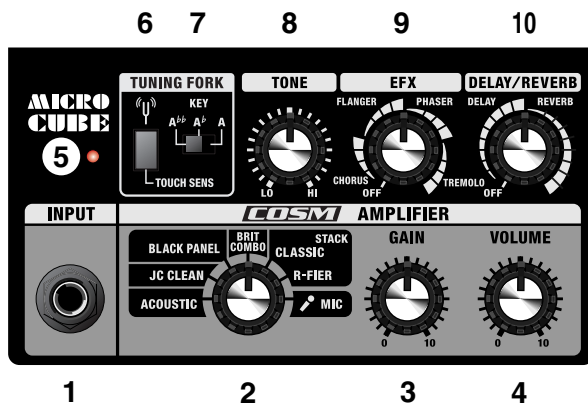

## 1. INPUT Jack

Connect your guitar or microphone here.

## 2. Type Switch

You can select from the following seven amp types:

### ACOUSTIC

This original amplifier model gives you a dynamic acoustic guitar sound using a standard electric guitar.

### JC CLEAN

This is a model of Roland's famous JC-120 Jazz Chorus guitar amplifier. The ultra-clean, ultra-flat sound offers a smooth.

This becomes more effective when used in combination with an external effector.

### BLACK PANEL

This is modeled on the classic Fender Twin Reverb amplifier, used in a wide variety of musical styles, from country to blues, jazz and rock. Exhibiting rich lows and a bright high end.

### BRIT COMBO

This is modeled on the Vox AC-30TB, the rock amplifier that created the Liverpool sound of the '60s. It can produce a broad range of sounds, from clean to overdrive, with increased distortion and greater power in the low-midrange when the amplifier's gain is boosted.

### CLASSIC STACK

This is modeled on the sound and response of a Marshall JMP1987. The legendary JMP1987 is renowned for its smooth tone and presence-perfect for classic and hard rock.

### R-FIER STACK

This is modeled on the MESA/Boogie Rectifier. This super high gain amp is capable of producing slash metal, grunge, and a wide range of other lead sounds.

### MIC

Select this position when microphone is connected.

- \* Howling could be produced depending on the location of microphones relative to speakers. This can be remedied by:
  1. Changing the orientation of the microphone(s).
  2. Relocating microphone(s) at a greater distance from speakers.
  3. Lowering volume levels.

### HINT

Use of the REC OUT / PHONES jack allows even better reproduction of the COSM-modeled sound.

- \* All product names mentioned in this document are trademarks or registered trademarks of their respective owners, and are not related to Roland Corporation. In this manual, these names are used as appropriate ways to indicate sounds that are simulated using COSM technology.

### 3. GAIN Knob

Adjusts the sensitivity at the input jacks.

### 4. VOLUME Knob

Adjusts the volume.

### 5. Power Indicator

This indicator lights when the unit is turned on.

- \* *When operating on battery power only, the unit's indicator will become dim during play when battery power gets too low.*
- \* *Sounds may distort easily or may cut off when played at high volume as the battery power begins to fade, but this is normal and does not indicate a malfunction. In such instances, either replace the batteries or use the AC adaptor included with the unit.*

### 6. TUNING FORK Switch

Press the switch to play the modeled tuning fork sound. Use this tone as the reference pitch when tuning your guitar.

The tuning fork volume is changed by how hard you press the switch. Adjust the overall volume with the GAIN knob (3) and VOLUME knob (4).

- \* *Pressing the TUNING FORK switch forcefully with the GAIN knob (3) and VOLUME knob (4) turned up may cause a sudden increase in volume. Be sure to monitor your volume levels carefully when using the amp at night and in other cases where high volumes should be avoided.*

#### HINT

- Select the tuning fork pitch with the KEY switch (7). Select "A" for normal tuning. Use the following procedure to tune your instrument.
  1. Press the TUNING FORK switch to start the tuning fork sound.
  2. Play the harmonic at the fifth fret of the fifth string over the tuning fork sound.
 

A wavering or "beating" pattern will be audible if the tuning fork and string are not in tune.
  3. Adjust the fifth string until the beats disappear.
  4. After tuning the fifth string to A, tune the other strings in reference to the fifth string.
- You'll find using the tuning fork easier if you use the TYPE switch (2) to select JC CLEAN or some other tone that does not include distortion, and turn the EFX and DELAY/REVERB to OFF.
- The tuning fork will continue sounding for a while after you push the TUNING FORK switch. Push the switch in gently to stop the sound in the middle of a continuing note; the duration of the tuning fork sound will be shortened, and it will stop briefly later.

### 7. KEY Switch

Use this to select the tuning fork pitch. Select "A" for normal tuning. To drop the tuning a half-step (semitone), select A $\flat$ , or select A $\flat\flat$  to lower the tuning a full step (whole tone) (A = 440 Hz).

### 8. TONE Knob

This adjusts the tone. Turn the knob clockwise for a brighter tone; to get a milder tone, turn the knob counterclockwise.

### 9. EFX (Effects) Knob

Turn this knob to chorus, flanger, phaser, or tremolo to select the corresponding effect. Turn the knob to adjust the amount of effect applied.

- \* *Graduations for CHORUS, FLANGER, PHASER, TREMOLO on a panel are for reference. Be sure to check the sound as you adjust the effects.*

#### CHORUS

In this effect, a slightly detuned sound is added to the original sound, giving the sound greater breadth and fullness.

#### FLANGER

This creates a flanging effect that creates a sort of spinning sensation with the sound.

#### PHASER

This effect adds a variable phase-shifted signal to the direct sound, giving the sound a swirling character.

#### TREMOLO

Tremolo is an effect that creates a cyclic change in volume.

### 10. DELAY/REVERB Knob

Turn this knob to DELAY or REVERB to switch to that effect. Turn the knob to adjust the amount of effect applied.

- \* *Graduations for DELAY, REVERB on a panel are for reference. Be sure to check the sound as you adjust the effects.*

#### DELAY

Turn the knob to change the time and amount of delay effect.

#### REVERB

Turn the knob to adjust the reverb level.



## 11. REC OUT/PHONES Jack

### When Using REC OUT

Use mono 1/4" phone plugs when connecting to this jack.

Use the VOLUME knob (4) to adjust the volume of the signal output from REC OUT to the appropriate level.

### When Using PHONES

Connect headphones to this jack.

The sound is output in mono.

- \* No sound is played through the unit's speaker while the REC OUT/PHONES jack is in use.

## 12. AUX IN Jacks

You can connect a CD player or other kind of device and have it play along with your guitar. Offers two types of jacks for external input; a 1/4" phone jack and a mini jack. However, the speaker and REC OUT / PHONES output is monaural.

- \* Determine the volume level by adjusting the volume control of the connected device. The MICRO CUBE's VOLUME knob (4) do not affect the input from AUX IN jacks.

## 13. POWER Switch

Turns the power on and off.

- \* This unit is equipped with a protection circuit. A brief interval (a few seconds) after power up is required before the unit will operate normally.
- \* Always make sure to have the volume level turned down before switching on power. Even with the volume all the way down, you may still hear some sound when the power is switched on, but this is normal, and does not indicate a malfunction.
- \* Depending on the knob settings, the volume at first may be too high when the power is turned on. Always be sure to turn down the volume before switching on the power.

## Switching the Power On and Off

- \* Once the connections have been completed, turn on power to your various devices in the order specified. By turning on devices in the wrong order, you risk causing malfunction and/or damage to speakers and other devices.

1. Make sure that all volume controls on the MICRO CUBE and connected devices are set to 0.
2. Turn on all the devices connected to the MICRO CUBE's INPUT and AUX IN jacks.
3. Turn on the MICRO CUBE.
4. Switch on any equipment connected to the MICRO CUBE's REC OUT/PHONES jack.
5. Adjust the volume levels for the devices.
6. Before switching off the power, lower the volume on each of the devices in your system and then TURN OFF the devices in the reverse order to which they were switched on.

## 14. AC Adaptor Jack

Connect the included AC adaptor to this jack.

- \* Use only the AC adaptor included with the MICRO CUBE.

## 15. Cord Hook

Hook the AC adaptor cord here (p. 9).

## 16. Security Slot (🔒)

<http://www.kensington.com/>

## Connecting the AC adaptor

### NOTE

Use only the AC adaptor included with the MICRO CUBE. Use of other AC adaptors may damage the amp or result in other problems.

To prevent the inadvertent disruption of power to your unit (should the plug be pulled out accidentally), and to avoid applying undue stress to the AC adaptor jack, anchor the power cord using the cord hook, as shown in the illustration.

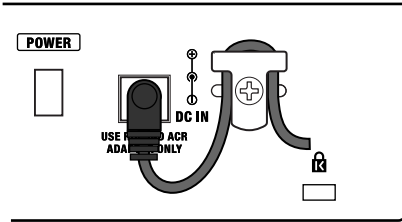

## A Note About Attaching the Strap

Attach the strap securely so that it does not easily become detached. If the strap is loose, and you use it that way when carrying the MICRO CUBE, the amp could be dropped, possibly resulting in damage or injury.

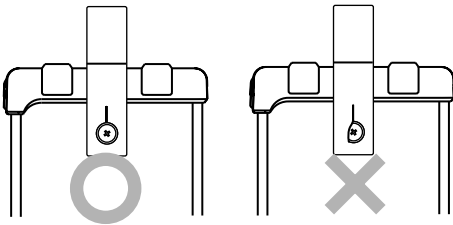

### NOTE

Use only the provided strap. The included strap is meant for exclusive use with the MICRO CUBE. Do not use this strap for other products.

### NOTE

Do not spin or swing the MICRO CUBE while holding it by the strap. This is extremely dangerous, as it may cause the strap to become detached; or, if the motion is repeated enough, may even break the strap.

## A Note About Batteries

In addition to the AC adaptor, the MICRO CUBE can also be powered with six AA batteries (optional). Insert the batteries as shown in the figure, making sure that the batteries are oriented correctly.

Use only alkaline batteries.

If there are batteries in the unit while an AC adaptor is being used, normal operation will continue should the line voltage be interrupted (power blackout or power cord disconnection).

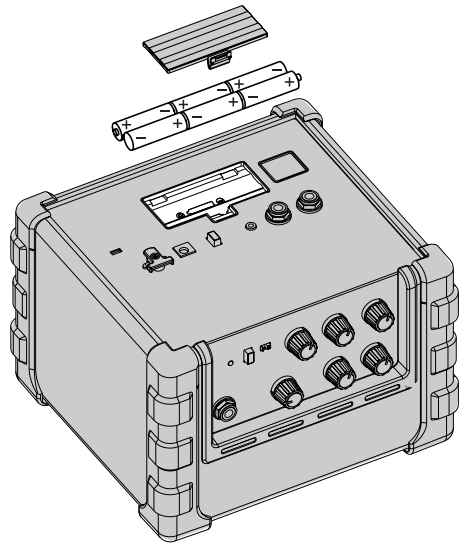

\* When installing or replacing batteries, always turn off the power on this unit and disconnect any other devices you may have connected. This way, you can prevent malfunction and/or damage to speakers or other devices.

\* Expected battery life under continuous use:  
Alkaline: approx. 20 hours  
This figure will vary depending on the actual conditions of use.

# Main Specifications

## ● Rated Power Output

2 W

## ● Nominal Input Level

INPUT: -10 dBu

AUX IN: -10 dBu

\*  $0 \text{ dBu} = 0.775 \text{ Vrms}$

## ● Speaker

12 cm (5 inches) x 1

## ● Controls

TYPE Switch

GAIN Knob

VOLUME Knob

TONE Knob

EFX Knob

DELAY/REVERB Knob

TUNING FORK

TUNING FORK Button

KEY Switch

POWER Switch

## ● Indicator

POWER

## ● Connectors

INPUT Jack: 1/4" phone type

REC OUT/PHONES Jack: Stereo 1/4" phone type

AUX IN Jacks: Stereo 1/4" phone type,  
Stereo miniature phone type

AC Adaptor Jack

## ● Power Supply

DC 9 V: AC Adaptor or

Dry Battery (LR6 (AA) type) (optional) x 6

\* *We recommend that alkaline batteries be used when installing the batteries.*

## ● Current Draw

185 mA

## ● Dimensions

244 (W) x 166 (D) x 226 (H) mm

9-5/8 (W) x 6-9/16 (D) x 8-15/16 (H) inches

## ● Weight

3.3 kg

7 lbs 5 oz

(excluding AC Adaptor and Battery)

## ● Accessories

AC Adaptor

Strap

Owner's Manual

\* *In the interest of product improvement, the specifications and/or appearance of this unit are subject to change without prior notice.*



This product complies with the requirements of European Directive 89/336/EEC.

For EU Countries

## FEDERAL COMMUNICATIONS COMMISSION RADIO FREQUENCY INTERFERENCE STATEMENT

For the USA

This equipment has been tested and found to comply with the limits for a Class B digital device, pursuant to Part 15 of the FCC Rules. These limits are designed to provide reasonable protection against harmful interference in a residential installation. This equipment generates, uses, and can radiate radio frequency energy and, if not installed and used in accordance with the instructions, may cause harmful interference to radio communications. However, there is no guarantee that interference will not occur in a particular installation. If this equipment does cause harmful interference to radio or television reception, which can be determined by turning the equipment off and on, the user is encouraged to try to correct the interference by one or more of the following measures:

- Reorient or relocate the receiving antenna.
- Increase the separation between the equipment and receiver.
- Connect the equipment into an outlet on a circuit different from that to which the receiver is connected.
- Consult the dealer or an experienced radio/TV technician for help.

This device complies with Part 15 of the FCC Rules. Operation is subject to the following two conditions:

- (1) This device may not cause harmful interference, and
- (2) This device must accept any interference received, including interference that may cause undesired operation.

Unauthorized changes or modification to this system can void the users authority to operate this equipment. This equipment requires shielded interface cables in order to meet FCC class B Limit.

For Canada

### NOTICE

This Class B digital apparatus meets all requirements of the Canadian Interference-Causing Equipment Regulations.

### AVIS

Cet appareil numérique de la classe B respecte toutes les exigences du Règlement sur le matériel brouilleur du Canada.

# Information

When you need repair service, call your nearest Roland Service Center or authorized Roland distributor in your country as shown below.

## AFRICA

### EGYPT

**Al Fanny Trading Office**  
9, EBN Hagar A1 Askalany Street,  
ARD El Golf, Heliopolis,  
Cairo 11341, EGYPT  
TEL: 20-2-417-1828

### REUNION

**Maison FO - YAM Marcel**  
25 Rue Jules Hermann,  
Chaudron - BP79 97 491  
Site Clotilde Cedex,  
REUNION ISLAND  
TEL: (0262) 218-429

### SOUTH AFRICA

**That Other Music Shop (PTY) Ltd**  
11 Melle St., Braamfontein,  
Johannesburg, SOUTH AFRICA  
P.O. Box 32918, Braamfontein 2017  
JOHANNESBURG, SOUTH AFRICA  
TEL: (011) 403 4105

### Paul Bothner (PTY) Ltd.

17 Werdmuller Centre,  
Main Road, Claremont 7708  
SOUTH AFRICA

P.O. BOX 23032, Claremont 7735,  
SOUTH AFRICA  
TEL: (021) 674 4030

## ASIA

### CHINA

**Roland Shanghai Electronics Co., Ltd.**  
5F, No.150 Pingliang Road  
Shanghai 200090, CHINA  
TEL: (021) 5580-0800

### Roland Shanghai Electronics Co., Ltd.

**(BEIJING OFFICE)**  
10F, No.18 Anluashi  
Chaoyang District, Beijing 100011  
CHINA  
TEL: (010) 6426-5050

### Roland Shanghai Electronics Co., Ltd.

**(GUANGZHOU OFFICE)**  
2/F., No.30 Si You Nan Er Jie Yi  
Xiang, Wu Yang Xin Cheng,  
Guangzhou 510600, CHINA  
TEL: (020) 8736-0428

### HONG KONG

**Ton Lee Music Co., Ltd.**  
Service Division  
22-32 Pun Shan Street, Tsuen  
Wan, New Territories,  
HONG KONG  
TEL: 2415 0911

### Parsons Music Ltd.

8th Floor, Railway Plaza, 39  
Chatham Road South, T.S.T.,  
Kowloon, HONG KONG  
TEL: 2333 1863

### INDIA

**Rivera Digitech (India) Pvt. Ltd.**  
409, Nirman Kendra Mahalaxmi  
Flats Compound Off. Dr. Edwin  
Moses Road, Mumbai-400011,  
INDIA  
TEL: (022) 2493 9051

### INDONESIA

**PT Citra IntriKama**  
Jl. Cikidang Timur No. 151-150  
Jakarta Pusat  
INDONESIA  
TEL: (021) 6324170

### KOREA

**Cosmos Corporation**  
1461-9, Seocho-Dong,  
Seocho Ku, Seoul, KOREA  
TEL: (02) 3486-8855

### MALAYSIA

**BENTLEY MUSIC SDN BHD**  
140 & 142, Jalan Bukit Bintang  
55100 Kuala Lumpur, MALAYSIA  
TEL: (03) 2144-3333

### PHILIPPINES

**G.A. Yungaco & Co. Inc.**  
339 Gil J. Payat Avenue  
Makati, Metro Manila 1200,  
PHILIPPINES  
TEL: (02) 899 9801

### SINGAPORE

**Swee Lee Company**  
150 Sims Drive,  
SINGAPORE 387381  
TEL: 6846-3676

### CRISTOFORO MUSIC PTE LTD

Blk 3014, Bedok Industrial Park E,  
#02-2148, SINGAPORE 489800  
TEL: 6243-9555

### TAIWAN

**ROLAND TAIWAN ENTERPRISE CO., LTD.**  
Room 5, 9th. No. 112 Chung Shan  
N.Road Sec.2, Taipei, TAIWAN,  
R.O.C.  
TEL: (02) 2561 3339

### THAILAND

**Theera Music Co., Ltd.**  
330 Verg NakornKasem, Soi 2,  
Bangkok 10100, THAILAND  
TEL: (02) 2248821

### VIETNAM

**Saigon Music Suite DTP-8**  
40 Ba Huyen Thanh Quan Street  
Hochiminh City, VIETNAM  
TEL: (08) 930-1969

## AUSTRALIA/NEW ZEALAND

### AUSTRALIA

**Roland Corporation Australia Pty. Ltd.**  
38 Campbell Avenue  
Dee Why West, NSW 2099  
AUSTRALIA  
TEL: (02) 9982 8266

### NEW ZEALAND

**Roland Corporation Ltd.**  
32 Shaddock Street, Mount Eden,  
Auckland, NEW ZEALAND  
TEL: (09) 3098 715

## CENTRAL/LATIN AMERICA

### ARGENTINA

**Instrumentos Musicales S.A.**  
Av Santa Fe 2055  
(1123) Buenos Aires  
ARGENTINA  
TEL: (011) 4508-2700

### BRAZIL

**Roland Brasil Ltda**  
Rua San Jose, 780 Sala B  
Parque Industrial San Jose  
Cotia - Sao Paulo - SP, BRAZIL  
TEL: (011) 4615 5666

### COSTA RICA

**JUAN BANSBACH Instrumentos Musicales**  
Ave. I, Calle 11, Apartado 10237,  
San Jose, COSTA RICA  
TEL: 258-0211

### CHILE

**Commercial Faculty II S.A.**  
Rut: 96.919.420-1  
Nataliel Cox #739, 4th Floor  
Santiago - Centro, CHILE  
TEL: (02) 688-9540

### EL SALVADOR

**OMNI MUSIC**  
75 Avenida Norte y Final  
Alameda Juan Pablo II,  
Edificio No.4010 San Salvador,  
EL SALVADOR  
TEL: 262-0788

### MEXICO

**Casa Veerkamp, s.a. de c.v.**  
Av. Toluca No. 323, Col. Olivar  
de los Padres 01780 Mexico D.F.  
MEXICO  
TEL: (55) 5668-6699

### PANAMA

**SUPRO MUNDIAL, S.A.**  
Boulevard Andres, Albrook,  
Panama City, REP. DE PANAMA  
TEL: 315-0101

### PARAGUAY

**Distribuidora De Instrumentos Musicales**  
J.E. Olear y ESQ. Manduvira  
Asuncion PARAGUAY  
TEL: (021) 492-124

### URUGUAY

**Todo Musica S.A.**  
Fonoteca Acuma de Figueroa 1771  
C. 11.800.4  
Montevideo, URUGUAY  
TEL: (02) 924-2335

### VENEZUELA

**Musicaland Digital C.A.**  
Av. Francisco de Miranda,  
Centro Parque de Cristal, Nivel  
C2 Local 20 Caracas  
VENEZUELA  
TEL: (212) 285-8586

## EUROPE

### AUSTRIA

**Roland Austria GES.M.B.H.**  
Siemensstrasse 4, P.O. Box 74,  
A-6063 RUM, AUSTRIA  
TEL: (0512) 26 44 260

### BELGIUM/HOLLAND/LUXEMBOURG

**Roland Benelux N. V.**  
Houtstraat 3, B-2260, Oevel  
(Western) BELGIUM  
TEL: (014) 975811

### CZECH REP.

**K-AUDIO**  
Kardasovska 626,  
CZ-198 00 Praha 9,  
CZECH REP.  
TEL: (2) 666 10529

### DENMARK

**Roland Scandinavia A/S**  
Nordhavnsvej 7, Postbox 880,  
DK-2100 Copenhagen  
DENMARK  
TEL: 3916 6200

### FRANCE

**Roland France SA**  
4, Rue Paul Henri SPAAK,  
Parc de l'Esplanade, F 77 462 St.  
Thibault, Lagry Cedex, FRANCE  
TEL: 01 60 73 7300

### FINLAND

**Roland Scandinavia As, Filial Finland**  
Elamentie 5  
FIN-01510 Vantaa, FINLAND  
TEL: (09) 68 24 020

### GERMANY

**Roland Elektronische Musikinstrumente GmbH.**  
Oestrasse 96, 22844 Norderstedt,  
GERMANY  
TEL: (040) 52 60090

### GREECE

**STOLLAS S.A.**  
Music Sound Light  
155, New National Road  
Patras 2642, GREECE  
TEL: 2610 435400

### HUNGARY

**Roland East Europe Ltd.**  
Warehouse Area 'DEPO' P/83  
H-2046 Torokbalint, HUNGARY  
TEL: (23) 511011

### IRELAND

**Roland Ireland**  
C2 Calmount Park, Calmount  
Avenue, Dublin 12  
Republic of IRELAND  
TEL: (01) 4294444

### ITALY

**Roland Italy S. p. a.**  
Viale delle Industrie 8,  
20120 Aresè, Milano, ITALY  
TEL: (02) 957-78300

### NORWAY

**Roland Scandinavia Avd. Kontor Norge**  
Liliekveien 2 Postboks 95  
Liljeaker N-0216 Oslo  
NORWAY  
TEL: 2273 0074

### POLAND

**MX MUSIC SP.Z.O.O.**  
ul. Gibraltarska 4,  
PL-03699 Warszawa POLAND  
TEL: (022) 679 44 19

### PORTUGAL

**Tecnologias Musica e Audio, Roland Portugal, S.A.**  
Cais Das Pedras, 8/9-1 Dto  
040-065 PORTO  
PORTUGAL  
TEL: (022) 608 00 60

### ROMANIA

**FBS LONIA**  
Piata Libertatii 1,  
535500 Gheorgheni, ROMANIA  
TEL: (266) 364 609

### RUSSIA

**MuTeK**  
3-Bogatyrskaya Str. 1.k1  
107 564 Moscow, RUSSIA  
SAUDI ARABIA  
TEL: (095) 169 5043

### SPAIN

**Roland Electronics de España, S. A.**  
Calle Bolivia 29, 08020  
Barcelona, SPAIN  
TEL: (93) 308 1000

### SWEDEN

**Roland Scandinavia A/S SWEDISH SALES OFFICE**  
Danvik Center 28, 2 tr.  
S-131 30 Nacka SWEDEN  
TEL: (08) 666 1020

### SWITZERLAND

**Roland (Switzerland) AG**  
Landstrasse 5, Postfach,  
CH-4452 Hingen,  
SWITZERLAND  
TEL: (061) 927-8383

### UKRAINE

**TIC-TAC**  
Mira Str. 19/108,  
P.O. Box 180  
295400 Mukachevo, UKRAINE  
TEL: (03131) 414-40

### UNITED KINGDOM

**Roland (U.K.) Ltd.**  
Atlantic Close, Swansea  
Enterprise Park, SWANSEA  
SA7 9EJ,  
UNITED KINGDOM  
TEL: (01792) 702701

## MIDDLE EAST

### BAHRAIN

**Moon Stores**  
No.16, Bab Al Bahrain Avenue,  
P.O.Box 247, Manama 304,  
State of BAHRAIN  
TEL: 211 005

### CYPRUS

**Radex Sound Equipment Ltd.**  
17, Diagorou Street, Nicosia,  
CYPRUS  
TEL: (022) 66-9426

### IRAN

**MOCO, INC.**  
No.41 Nike St., Dr.Shariyati Av.,  
Robertsy Gharah Miramad  
Tehran, IRAN  
TEL: (021) 285-4169

### ISRAEL

**Haliit P. Greenspoon & Sons Ltd.**  
8 Zolotarevsky Hachnya St.  
Tel-Aviv-Yafa ISRAEL  
TEL: (03) 6823666

### JORDAN

**AMMAN Trading Agency**  
245 Prince Mohammad St.,  
Amman 1118, JORDAN  
TEL: (06) 464-1200

### KUWAIT

**Easa Hussein Al Youusif Est.**  
Abdulali Salem Street,  
Safat, KUWAIT  
TEL: 243-6399

### LEBANON

**Chahine S.A.L.**  
Gergé Zaidan St., Chahine Bldg.,  
Achrachieh, P.O.Box: 16-5857  
Beirut, LEBANON  
TEL: (01) 20-1441

### QATAR

**Al Emadi Co. (Badié Studio & Stores)**  
P.O. Box 62, Doha, QATAR  
TEL: 4423-554

### SAUDI ARABIA

**adWaliah Universal Electronics APL**  
Corniche Road, Aldossary Bldg.,  
1st Floor, Alkhabr,  
SAUDI ARABIA  
P.O. Box 2154, Alkhabr 31952  
SAUDI ARABIA  
TEL: (081) 898 2081

### SYRIA

**Technical Light & Sound Center**  
Khalid Ebn Al Walid St.  
Bldg. No. 47, P.O.BOX 13520,  
Damascus, SYRIA  
TEL: (011) 223-5384

### TURKEY

**Ant Musik Aletleri Ithalat Ve Ihracat Ltd Sti**  
Siraselvler Caddesi Siraselvler  
Pasaji No:74/20  
Taksim - Istanbul, TURKEY  
TEL: (0212) 249324

### U.A.E.

**Zak Electronics & Musical Instruments Co. L.L.C.**  
Zabeel Road, Al Sheroq Bldg.,  
No. 14, Grand Floor, Dubai, U.A.E.  
TEL: (04) 3360715

## NORTH AMERICA

### CANADA

**Roland Canada Music Ltd. (Head Office)**  
5480 Parkwood Way Richmond  
B. C., V6V 2M4 CANADA  
TEL: (604) 270 6626

### Roland Canada Music Ltd. (Toronto Office)

170 Admiral Boulevard  
Mississauga On L5T 2N6  
CANADA  
TEL: (905) 362 9707

### U. S. A.

**Roland Corporation U.S.**  
5100 S. Eastern Avenue  
Los Angeles, CA 90040-2938,  
U. S. A.  
TEL: (323) 890 3700

As of November 1, 2003 (Roland)